

Microscopic Void Characterization for Assessing Aging of Electric Cable Insulation Used in Nuclear Power Stations

D. A. Horvath, D. C. Wood, and M. J. Wylie

Advent Engineering Services, Inc.

ABSTRACT

In the last 20 years no new nuclear power plants have been ordered in the US and many are being decommissioned. As a result, over half of the nuclear utility owners are expected to seek to extend the license term of their operating plants under approaches allowed by Title 10 Code of Federal Regulations Part 54 (the License Renewal Rule). An essential element of this process is demonstrating the effects of aging of electric cable insulation "will be adequately managed to assure its intended function will be maintained over the license renewal term" typically 20 years. However, a reasonable, reliable method of assessing remaining life of electric cable insulation has continued to elude the nuclear industry. Building on the research efforts of Laurent and Mayoux and others, this paper discusses the development of a promising approach for assessing electric cable life using void characterization by microscopic techniques. Analysis of research to date has shown that void size and density are not only an indication of degree of aging but proximity to a limiting parameter value may be correlated to a level of remaining life for a given set of environmental and operation imposed stresses. Additional complexity is introduced by the nuclear plant operating environment. Not only is normal aging multi-stressor (e.g., thermal, radiation, and others) in nature, but in many station applications a degree of margin for "accelerated aging" during a design basis event must also be considered.

1 INTRODUCTION

No new nuclear power plants have been ordered in the US since 1979 and several have been shutdown permanently. In order to continue to meet the growing energy needs of the US, it will be necessary to extend the term of the operating license of many and likely most of the remaining plants. The framework of such a license term extension is established in Title 10 of the Code of Federal Regulations Part 54 - also known as the License Renewal Rule. An essential part of this process is demonstration that the effects of aging can be managed to the extent that essential equipment functions will be maintained. Electric cable has been identified to be a key part of this demonstration and evidence of continued cable integrity is needed to support license renewal. An economical form of testing as an alternative to full-scale cable replacement is sought by the industry. [1]

This paper will report on a new promising technique for reliably and cost-effectively confirming adequate remaining life of electric cable insulation.

2 REGULATORY ISSUES FOR CABLES

Nuclear power station license renewal beyond its normal 40 year term requires a comprehensive review and approval by

the US Nuclear Regulatory Commission (NRC). This review assures that the Station Owner's approaches, testing, and evaluations for aging effects management are acceptable for the extended license term. Recently [2], the NRC has directed its staff to focus on areas where existing plant programs have been determined to be inadequate and should be augmented for license renewal. The basis for determining inadequacy is found in the NRC's "Generic Aging Lessons Learned" (GALL) Report [3]. Environmental Qualification (EQ) is an example of such an existing program. EQ is documented evidence that essential equipment will be functional even at the end of required life at which time exposure to the harsh environment effects of a design basis event are assumed to occur.

In essence, EQ Programs already require that aging be evaluated but for license renewal, would need to address the additional aging for the extended license period - typically another 20 years. Separate from license renewal, the NRC has identified as a generic issue (GSI-168) that EQ Programs do not adequately address remaining cable insulation life. Regardless of whether nuclear station owners seek license renewal, it may be necessary to address electric cable aging via some type of testing.

Until now, there have been no acceptable nondestructive monitoring techniques to measure the condition of electric insulation *in situ*.

3 LIMITATIONS OF PRESENT TECHNIQUES

In general, testing of cable insulation has been limited to electrical testing, which is go/no go results oriented or to trending of mechanical properties (such as loss of elongation retention and hardness).

Many nuclear station owners perform high voltage insulation resistance (IR) testing or measure polarization index (PI), a time delay variation form of IR testing. Some plants additionally perform time domain reflectometry. However, most attempts at gleaning any useful information on remaining life from such testing are controversial at best. The best conclusion that can be drawn from such electrical testing is the electric insulation is acceptable at present with no guarantee for future continued integrity or operational acceptability.

Measurement of mechanical properties such as jacket material hardness or loss of elongation retention are not indicative of internal insulation integrity, are not representative of electrical properties, and can be destructive of the sample. These techniques have not provided useful, trendable remaining life information.

In recent years, some new techniques such as Oxygen Induction Time and Fourier Transform InfraRed have been developed but these techniques either rely on indirect (and often inconsistent) insulation material properties and require destructive testing.

Confirmation of the acceptability of cable insulation remaining life is essential to ensure continued long-term reliable nuclear power plant operation. A more accurate approach is needed to confirm continued acceptable margin in cable insulation life or to establish end of life for insulation subjected to aging and post-design basis event harsh environments.

4 DEFINING END OF LIFE

Nuclear power stations have many unique considerations such as:

- tens of to hundreds of thousands of installed cable making complete replacement impractical,
- many areas inaccessible for inspection or testing for periods of time of 18 months or more,
- multiple cable manufacturers representing diverse insulation system jacket and dielectric material combinations, and
- concurrent temperature and radiation aging during the plant's normal life license term.

In addition, for a limited number of essential equipment cables, continued operability is required during a harsh environment assumed to occur at the end of the plant's license

term. This harsh environment (an accelerated aging period) is postulated to be caused by a design basis event such as a major steam system pipe break and can produce elevated levels of temperature, pressure, radiation dose, humidity, and chemical spray.

As with most facilities, nuclear stations contain power, instrument, and control cables. The end of life for a power cable (normally energized at near rated or at an appreciative amount of current) would typically be based on preventing significant partial discharge to the point where current carrying functionality is affected.

End of life for instrument and control cable is based on preventing excessive leakage current such that instrument accuracy or controlled equipment operation is detrimentally affected.

In both cases, margin to end of life must be confirmed for the license term.

5 VOID CONTENT AS AN INDICATOR OF INSULATION "HEALTH"

Discharges within cavities (voids) in solid insulating systems has long been associated with gradual degradation and eventual dielectric failure. Studies by the C. Laurent and C. Mayoux of Laboratoire de Genie Electrique, [4, 5] have shown that gas-filled cavities (or voids) can originate in a wide range of solid dielectric systems through many mechanisms including differential thermal expansion, incomplete impregnation or excessive mechanical stress, or improper process control. Such cavities can originate during the manufacturing process or over a lifetime of operation as a result of environmental and operational stresses. Progressive deterioration caused by discharges in gas filled cavities has long been known to be one of the major factors limiting the life of cables. [6]

Voids will grow in size and the void density will increase as a function of energy absorption (heat, radiation dose, electrical field induced stress, etc.). The insulation's polymer structure consists of long, intertwined molecular combinations of carbon, hydrogen, and oxygen atoms. When the polymer absorbs energy while in the proximity of oxygen or ozone, radicals and various gases are produced. The resulting chemical reaction products include carbon dioxide, carbon monoxide, water vapor, and other volatile gaseous molecules. Some or many of these gaseous reaction products will create new void sites or accumulate in nearby voids contributing to an increase in density and size in a manner which will, therefore, be a function of the cable's insulation aging degradation rate.

It is also possible that voids would additionally be formed from physical rearrangements of the molecules due to crystallization from aging. The voids distributed throughout the insulation structure will increase in size and the polymer structure of the material will weaken. The result is that the net or equivalent amount of insulation between the separated

conductors decreases. A point will be reached at which partial discharge and/or voltage breakdown between nearby conductors of high potential can occur.

It can also be shown that the existence of voids in insulation increases the energy storage ability of the electric field created between adjacent, differently energized conductors. Therefore, the size and density of voids affects the capacitance of the dielectric and, therefore, also affects leakage current when the conductors are subject to different time varying electric potentials. High void content causes high equivalent capacitive effects, which can lead to excessive leakage current - a primary failure criterion for instrument and control cables.

The voids contain gases, which are easily ionized when subjected to an electric potential. This ionization reduces the effective thickness of the insulation correspondingly. As the void sizes increase with age, the equivalent remaining thickness of the insulation reduces to a point where a breakdown (discharge) can occur. The limiting equivalent remaining insulation thickness that is just large enough to prevent breakdown can then be determined. By modeling the void growth from service condition factors (including post-nuclear accident harsh environment effects), the remaining life can be accurately predicted. It will be necessary to determine by experimental test at what void content (for a given insulation material) end of life occurs.

For a given temperature, the production rate for each single gas molecule product should be approximately constant. Using the ideal gas law, the rate of increase in the volume occupied by that gas (assumed to accumulate in the voids) will be directly proportional to the gas molecule production rate, which is a constant for a given temperature. Therefore:

$$dV/dt = K, \quad \int dV = \int K dt, \quad \text{and } V(t) = V_0 + Kt$$

Where: V = Volume occupied by voids

t = Time

K = Calibrateable constant

V₀ = Volume at t = 0

If the voids are modeled as approximately spherical and the void size increase effect dominates over the density increase effect as expected then:

$$V = (4/3)\pi r^3 n, \text{ then } V_0 + Kt = (4/3)\pi r^3 n$$

Where: n = number of voids

r = equivalent radius of each void.

Therefore, the size of the voids will approximately follow the cubic root of the elapsed time, which perhaps explains the long life, in general, of electric insulation. This relationship also assumes no pressure buildup in the voids and no leakage of gases from the insulation medium. These two considerations would further reduce the void size increase rate but allows the above relationship to be conservatively high for modeling purposes. This approximation is also simplistic in

that it does not account for the accelerated growth, which occurs near end of life from space charge buildup and self-heating effects. [7]

As a first-order approximation, it is expected that the gaseous production rate will be a linear function of temperature, which allows a determination of void size growth rate for different elevated temperatures. It is expected that early in life, void density will increase and then level off as a sufficient number of gas collection sites are created. After a certain point, long before the onset of any degradation of concern, the dominant factor will be void size growth.

More accurate computer modeling can be accomplished by considering multiple gaseous production reactions and gaseous loss rates and by calibrating via use of experimental test results.

Recent papers by C. Dang *et al* [8] and A.C. Gjaerde [9] summarize advantages and disadvantages of current aging models including theories, multifactor effects and validating data. Relationships deduced from these aging models include a decrease in insulation life when:

- applied electric field goes up,
- applied electric field frequency goes up,
- increased exposure time to moisture,
- increased residual stresses (thermal, electric, mechanical),

Also, for increased exposure to moisture, the applied voltage causing breakdown decreases. Each of these relationships can be correlated with increasing void content and computer modeled with the aid of experimental calibration.

6 VOID DETECTION

Previous research results have allowed successful void detection and imaging. [1] Electric insulation void size and density information may be established via optical, electron, or acoustic microscopy. Use of acoustic microscopy was found to require prior calibration by other means. However, once calibrated, acoustic microscopy is a promising tool for *in situ* detection and measurements such as in Figure 1.

The transducer (A) converts electrical signal to acoustic signal and converts return (reflected) acoustic signal to electrical signal. The signal transmitter (B) sends an electrical signal of the required frequency and pulse shape / width to satisfy the control setting. The control setting (C) inputs the desired insulation depth window to be viewed / analyzed. The control setting can be adjusted to ignore any reflections from the cable jacket or electrical conductors. The amplifier / discriminator (D) boosts the received signal and screens to minimize noise and optimize the desired signal characteristics. (For example, discriminate to view only the reflections indicative of the control setting depth range, which corresponds to a window of reflected time for each transmitted

pulse.) An output signal is also available for display of an image representative of actual void sizes and dispersion within the insulation medium.

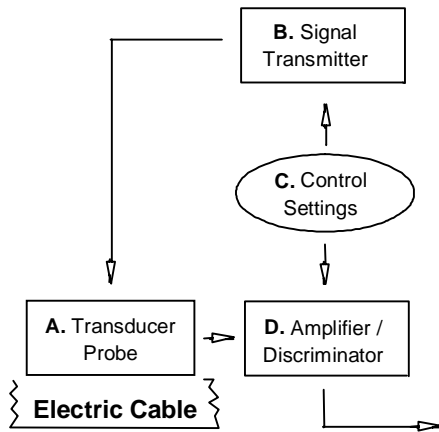

Figure 1 Void Detection and Processing

The principle of acoustic microscopy is that sound waves reflect at interfaces of material density decreases such as from solid polymer to a gaseous void site. The sharper the discontinuity in density, the stronger the reflected wave. Sonoscan, Inc. volunteered use of its C-Mode Scanning Acoustic Microscope (C-SAM) Series D6000 for this research. This C-SAM operates at 10 to 100 MHz, which was found to provide the desired resolution. The C-SAM through adjustment of the observed time interval of the reflected wave was found to be capable of filtering out reflections from the cable's jacket material. Therefore, images of the electric insulation's internal void characteristics were readily apparent. Figures 2 and 3 provide two sample views of electric insulation using acoustic microscopy. Figure 2 is a view of a jacketed cable as it would appear if monitored in the field (*in situ*). Figure 3 is a prepared (cut) sample view.

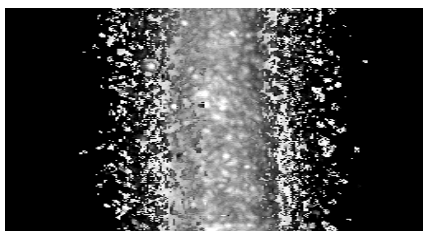

Figure 2 Aged Ethylene Propylene Viewed with C SAM at 15 MHz. The bright spots are reflected void formations.

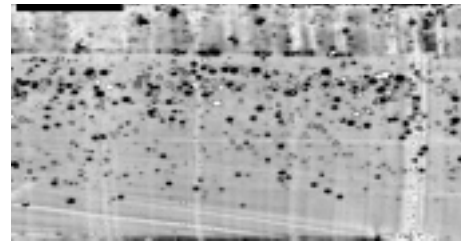

Figure 3 Aged Polyethylene Viewed with C SAM at 50 MHz. In this inverted image the voids are dark spots.

7 VOID CORRELATION TO ESTIMATED REMAINING LIFE

As stated earlier, void size and density are indicative of remaining life through comparison to end of life criteria values. Such a correlation can be performed as shown in Figure 4 and described below.

Note that this technique requires no baseline or trending. It is not necessary to know past void history. Only the present level of proximity or margin to limiting void parameters is required to establish remaining life.

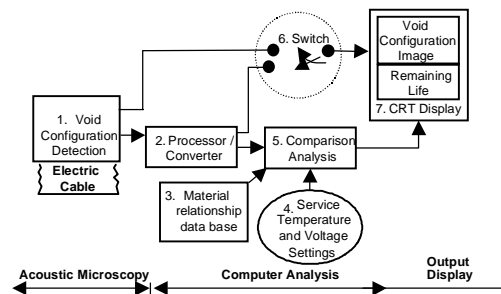

Figure 4 Electrical Insulation Life Determination Using Acoustic Microscopy and Void Analysis

Void information is detected (1) using a system similar to that shown in Figure 1 and sent to a Switch (6) as well as to a Processor / Converter (2). The Processor / Converter allows a conversion to a digital signal which is analyzed and converted to an equivalent insulation medium of uniform void size and density (homogeneous dispersion throughout the insulation medium). Equivalent is defined as the same (or somewhat more limiting in terms of) susceptibility for production of an electrical partial discharge path across the electrical insulation medium under design potential conditions. This equivalent void size and density configuration is provided as one input to the comparison analysis device (5). An analog output signal representative of this "equivalent configuration" could also be made available for display (7) via switch (6).

Using void characteristics and partial discharge failure prediction techniques, relationships for service temperature and limiting void size and density corresponding to the appropriate failure criterion are available for various insulation materials [from data base (3)] as the second input to the comparison analysis performed by device (5).

Desired future service temperature and design voltage conditions are set in via setting (4). Inputs from (2), (3), and (4) are used to determine remaining life in device (5) by first determining the margin between actual equivalent void configuration and the limiting (impending failure) configuration and then calculating void growth rate, which is a function of temperature and material type. The output is a numerical or temperature dependent signal, which is sent to the display monitor (7) such that either remaining life for a given temperature or a graph of remaining life vs. temperature can be displayed.

The Display Switch (6) allows monitoring on device (7) of either a "raw" (unprocessed) reflected signal representative of the actual void configuration within the insulation medium or the equivalent void configuration.

This display device (7) is envisioned to be a CRT such as that typically used by a personal computer. The upper portion of the display will show an image of the insulation medium's void configuration (processed or unprocessed). The lower portion will provide the remaining life result (for a specified temperature or as a function of temperature).

8 CONCLUSIONS

The above described approach may be applied to low, medium, or high voltage cable and thus used to predict the degree of aging and the amount of remaining life based on measurement of a solid dielectric material's internal void sizes and density. This technique relates void sizes to either the material's proximity for partial discharge breakdown or excessive leakage currents. These two failure criteria are true electrical indicators of end of life for electric insulation. Therefore, this method will provide a much more accurate indication of remaining life than approaches that rely on mechanical properties such as hardness and elongation retention or less informative parameters such as insulation resistance. Also no baseline or trending is required. However, prudence would require that measurements be made at limiting (high environmental / operational stress points) on the cable. This method will allow owners of power plants and other facilities to improve operational reliability or otherwise assure that electric cable aging concerns do not exist by performing relatively simple *in situ* sampling of cable insulation.

ACKNOWLEDGEMENTS

The authors wish to acknowledge the prior void detection research efforts by S.M Avila of Advent Engineering, the

assistance of Sonoscan, Inc., the advice of Associate Professor D. C. Martin and the facilities of the University of Michigan (Ann Arbor) Material Science and Engineering Department, and the many scientists and engineers who have contributed to electrical insulation void theory over the past ten years (not the least of which includes the inspiring work of C. Laurent and C. Mayoux).

REFERENCES

- (1) S. M. Avila and D.A. Horvath, "Microscopic Void Detection as a Prelude to Predicting Remaining Life in Electric Cable Insulation", to appear *Proceedings of International Topical Meeting on Nuclear Plant Instrumentation, Controls, and Human Machine Interface Technologies (NPIC & HMIT)*, November 2000.
- (2) US Nuclear Regulatory Commission, Staff Requirements Memorandum (SRM), August 27, 1999.
- (3) US Nuclear Regulatory Commission, "Generic Aging Lessons Learned" Draft Report, December 6, 1999.
- (4) C. Laurent and C. Mayoux, "Partial Discharge - Part XI: Limitations to PD as a Diagnostic for Deterioration and Remaining Life", *IEEE Electrical Insulation Magazine*, Vol 8, March/April 1992, pp 14-17.
- (5) C. Mayoux, "Aging of Polymeric Insulating Materials in Power Cables", *IEEE Transaction on Dielectrics and Electrical Insulation*, Vol 4, December 1997, pp 665-673.
- (6) C. Mayoux and C. Laurent, "Contribution of Partial Discharges to Electrical Breakdown of Solid Insulating Materials", *IEEE Transaction on Dielectrics and Electrical Insulation*, Vol 2, August 1995, pp 641-652.
- (7) Y. Zhang, J. Lewiner, and C. Alquie, "Evidence of Strong Correlation Between Space-Charge Buildup and Breakdown in Cable Insulation", *IEEE Transaction on Dielectrics and Electrical Insulation*, Vol 3, December 1996, pp 778-783.
- (8) C. Dang, J.-L. Parpal, and J.-P. Crine, "Electrical Aging of Extruded Dielectric Cables: Review of Existing Theories and Data", *IEEE Transactions on Dielectrics and Electrical Insulation*, Vol 3, April 1996, pp 237-247.
- (9) A.C. Gjaerde, "Multifactor Ageing Models - Origin and Similarities", *IEEE Electrical Insulation Magazine*, Vol 6, January/February 1997, pp 6-13.